

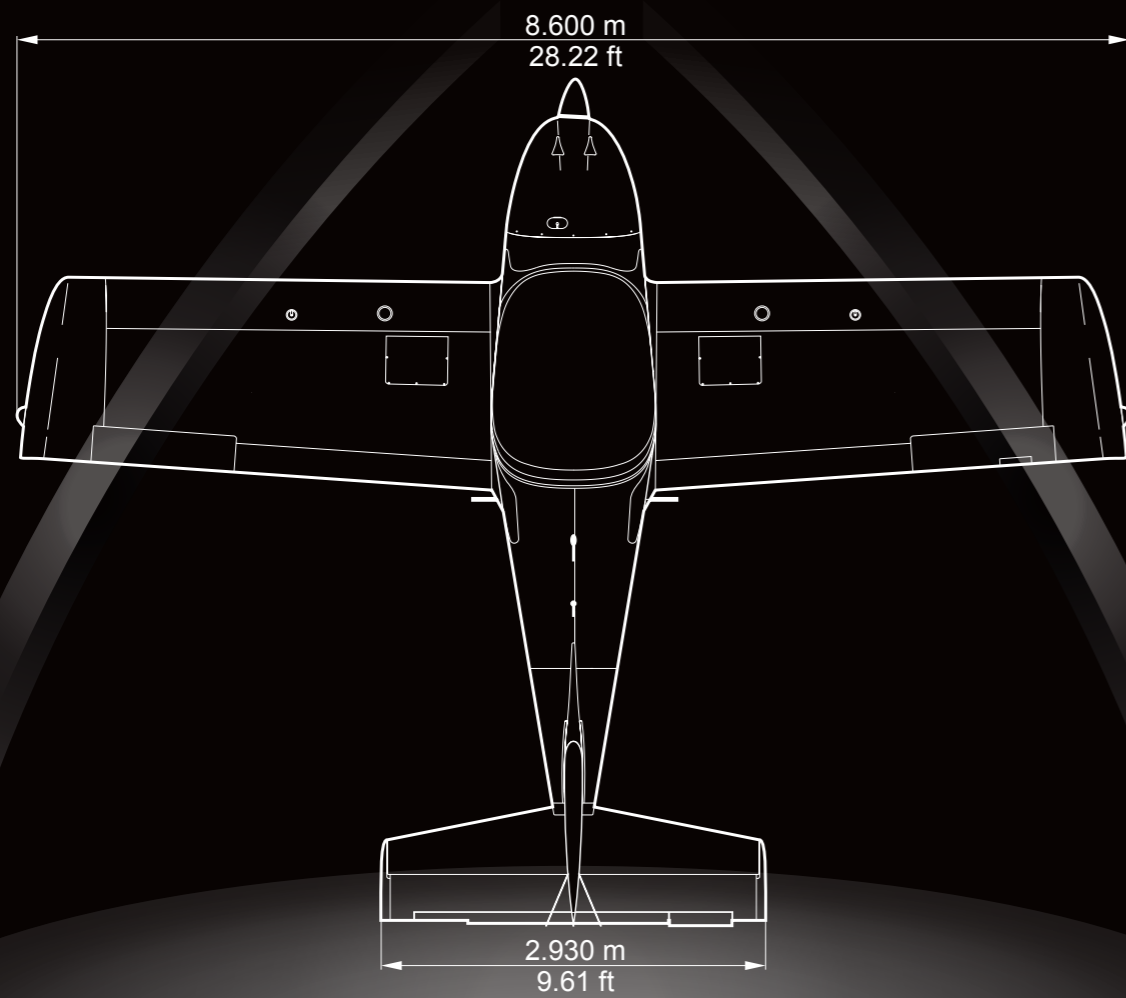

CZECH
SPORT AIRCRAFT

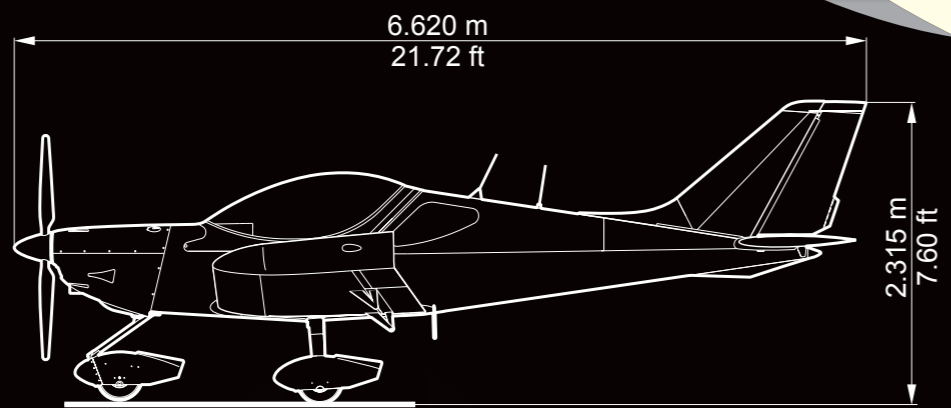

OFFICIAL AUTHORISED TRADING PARTNER



AviationTrading

sales@czechsportaircraft.com

info@aviationtrading.eu

www.czechsportaircraft.com

www.aviationtrading.eu

Photo by Michael Doorey



PRODUCT OVERVIEW

The current production of Czech Sport Aircraft comprises the SportCruiser and the PS-28 Cruiser. Both aircraft are double-seat aircraft of full metal construction, arranged as low-wing mono-planes with cantilevered wings and conventional empennage. The SportCruiser and PS-28 Cruiser are essentially differentiated in terms of their certification and thus their market application. Currently a total of over 500 SportCruiser and PS-28 Cruiser have been delivered. Over 200 aircraft are operating in the USA and almost 200 aircraft are operating in Europe where the company is enjoying significant sales success.

The SportCruiser is certified in the LSA category according to USA ASTM regulations and can be operated in countries recognising these regulations, e.g. USA, South Africa, Australia and some South American countries. The SportCruiser is the perfect platform for basic and advanced flight training, air clubs, basic military pilot training, general recreational use and air tourism.

THE NEW BENCHMARK FOR FLIGHT TRAINING

Current statistics show that over 50% of aircraft delivered by Czech Sport Aircraft are used by flight schools and air clubs in a basic and advanced training role as well as for time building. As a very well-established brand and household name in North America, Australia & Oceania and Africa, the SportCruiser has gained a strong reputation in these markets as a platform for flight training. As of December 2014, over 20 flight schools across the USA alone were operating the SportCruiser. The facts on the market today clearly confirm the leadership of the SportCruiser within the flight training market.

This modern state-of-the-art aircraft provides significant operational benefits to flight training organisations and air clubs as well as offering an attractive modern alternative for the new generation of pilot compared to the old generation of aircraft in the aging training fleets throughout the world. The excellent flight characteristics of the aircraft and robust construction of the airframe are perfectly suited to entry-level students and this makes the SportCruiser the ideal platform for training purposes. In addition, due to the highest standards of safety, superior performance, ease of maintenance and low through-life operating costs, the SportCruiser has quickly established itself as the new benchmark for flight training throughout the world.

LOW OPERATIONAL COSTS

Through-life costs are a major consideration in the decision-making process for the acquisition of a new aircraft. The new-

generation SportCruiser represents the lowest operational costs in its class and can provide considerable benefits in flight school operations compared to older aircraft of a different category. Together with a very competitive acquisition price and the integration of modern technologies, this makes the SportCruiser a very attractive proposition for all user groups.

MAINTENANCE-FRIENDLY AIRCRAFT

Due to the intelligent construction of the aircraft coupled with certain elements of design and applied technologies, the SportCruiser is perceived by operators to be a very maintenance-friendly aircraft. The associated simplified procedures makes the SportCruiser an ideal solution specifically for flight schools and operators of large fleets.

ROBUST CONSTRUCTION

Czech Sport Aircraft currently holds both Production Organisation Approval and Design Organisation Approval from the European Aviation Safety Agency (EASA). The company's technological excellence and dedication to innovation, makes Czech Sport Aircraft a leader in the Light Sport Aircraft segment of the General Aviation market. Due to the choice of materials and processes involved in the production of the SportCruiser, the aircraft demonstrates a very robust construction perfectly suited to exploitation in a flight training role.

MOST SPACIOUS & REFINED COCKPIT IN ITS CLASS

The SportCruiser boasts by far the most spacious and ergonomic cockpit in its class and a level of comfort and refinement that is second to none. The first-class choice of fabric and leather upholstery, advanced on-board climate control and defogging systems and the ease of control and endurance of the aircraft provide for the SportCruiser being widely recognised as a true cross-country aircraft.

FLEXIBILITY OF LUGGAGE SPACE GUARANTEED

With unique baggage lockers integrated into both wing sections of the aircraft as well as a spacious baggage compartment located to the rear of the cockpit, the SportCruiser will always guarantee optimum flexibility for that weekend away. Each individual wing locker is capable of accommodating up to 10kg of luggage, providing the possibility to transport up to a total of 38kg of luggage depending on available useful load.

SportCruiser

TECHNICAL SPECIFICATION

Engine:	Rotax 912 ULS2	Cruise speed at 3000 ft and 75% power:	93 KIAS (172 km/h)
Power:	73.5 kW, 100 HP at 5800 RPM	Max. horizontal speed:	119 KIAS (220 km/h)
Fuel:	Mogas RON 95, Avgas 100 LL, EN 228	V _{NE} :	138 KIAS (255 km/h)
Propeller:	Woodcomp Klassic 170/3/R Sensenich Fixed 3-blade (*)	Stall speed V _{SO} :	31 KIAS (55 km/h)
		Climb rate:	825 ft/min (4.2 m/s)
Wingspan:	8.6 m (28.22 ft)	Take-off distance to 50 ft (15 m):	
Length:	6.62 m (21.72 ft)	Concrete:	1270 ft (387 m)
Height:	2.315 m (7.60 ft)	Grass:	1499 ft (457 m)
Wing surface area:	12.3 m ² (132,4 sq ft)	Landing distance:	
Cockpit width:	1.170 m (3,85 ft)	Concrete:	1188 ft (362 m)
MTOW:	600 kg (1320 lbs)	Grass:	1109 ft (338 m)
Empty weight (Classic with reduced configuration):	381 kg (840 lbs)	Range (30 min. reserve):	512 nm (948 km)
Max. baggage weight in rear compartment:	18 kg (40 lbs)	Endurance:	5 hours 26 min
Max. baggage weight in each wing locker:	10 kg (22 lbs)	Fuel capacity:	114 l (30 US gal.)
		Average fuel consumption:	17.5 l (4.6 US gal./1 hour)

STANDARD INSTRUMENTS



SportCruiser SVAP Light

1x SkyView SV-D1000T MFD screen with back-up battery SV-BAT-320
Air data, attitude, heading reference system. SV-ADAHRS-200
1x Skyview SV-GPS-250 built-in GPS
SV-MAP-270 navigation software
SkyView Internal AutoPilot
SkyView Internal Transponder, SV-XPNDR-261 (S-Mode Class 1)
SV-EMS-220 Engine Monitoring Module
OAT Probe
Pitch Trim Indicator on MFD
Aileron Trim Indicator on MFD
ADS-B receiver SV-ADSB-470
VHF - NAV/COM
Intercom
ELT
Stall Warning
Ballistic Recovery System (*)
LiPo Battery (**)



SportCruiser SVAP+

2x SkyView SV-D1000T MFD screens both with back-up battery SV-BAT-320
Primary air data, attitude, heading reference system. SV-ADAHRS-200
Back-up air data, attitude, heading reference system. SV-ADAHRS-201
SkyView SV-GPS-250 built-in GPS
SV-MAP-270 navigation software
SkyView Internal AutoPilot
SkyView Internal Transponder, SV-XPNDR-261 (S-Mode Class 1)
SV-EMS-220 Engine Monitoring Module
OAT Probe
Pitch Trim Indicator on MFD
Aileron Trim Indicator on MFD
Garmin GPS 796
ADS-B receiver SV-ADSB-470
VHF - NAV/COM
Intercom
ELT
Stall Warning
Ballistic Recovery System (*)
LiPo Battery (**)

(*) Optional Equipment
(**) Option only in combination with Ballistic Recovery System