

# DETAIL ÚSTÍ DETAIL OF FINISH ( 5 : 1 )

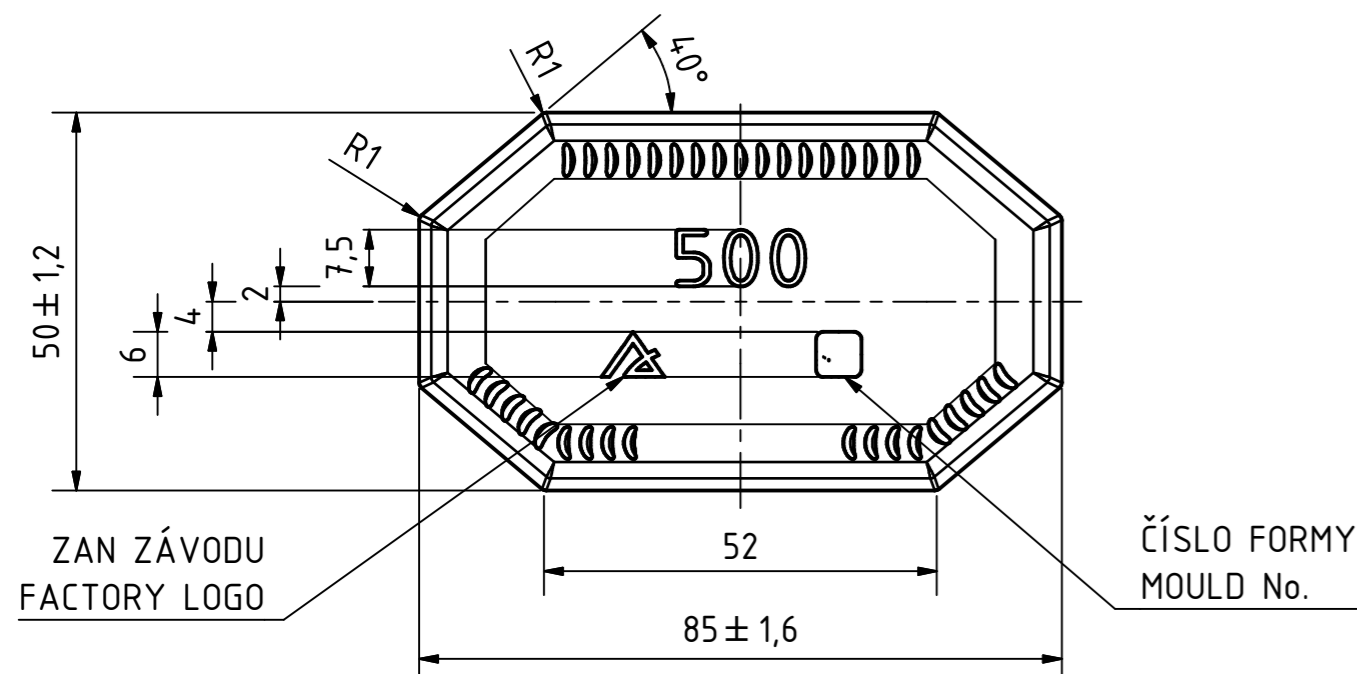
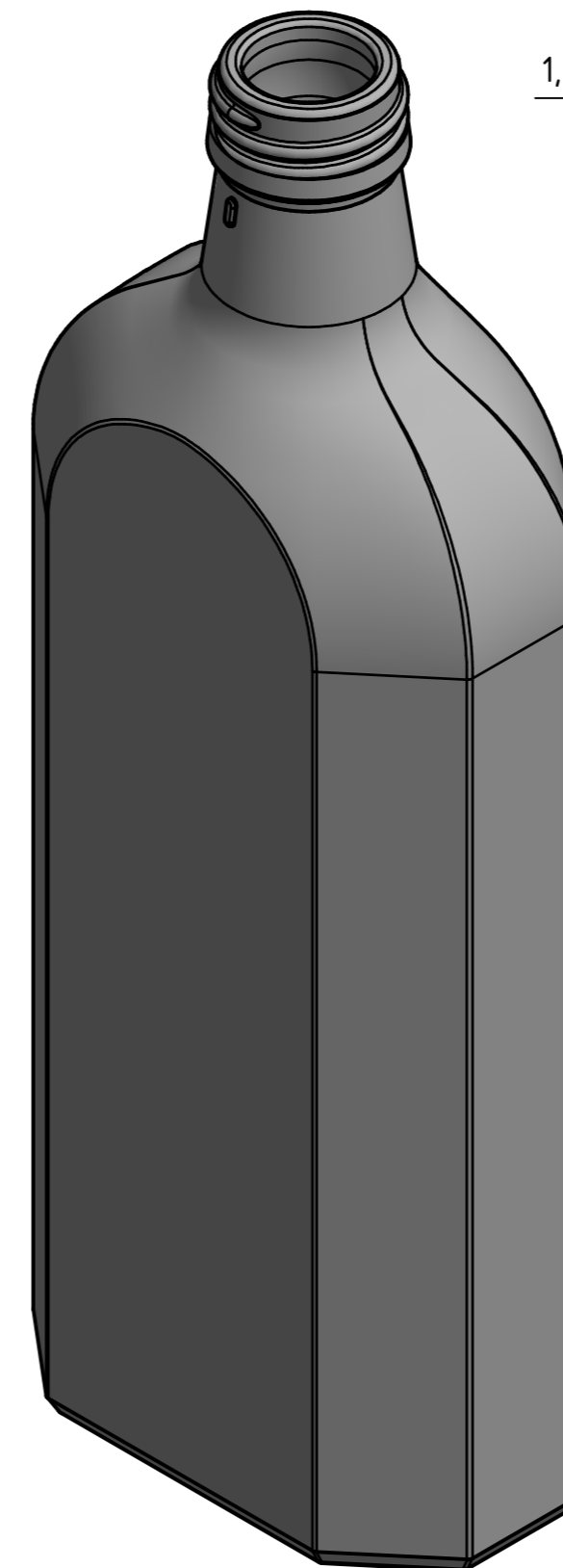
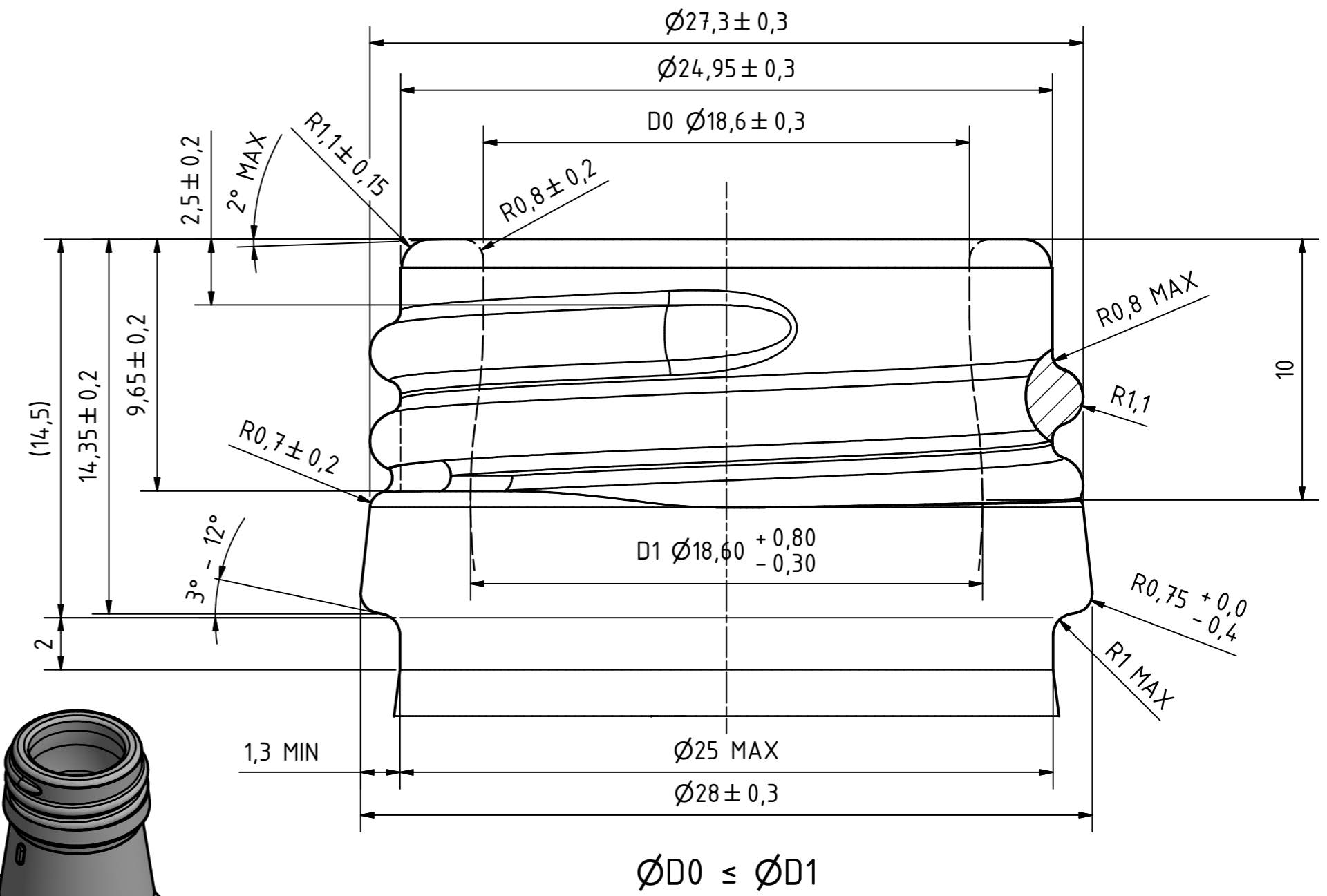
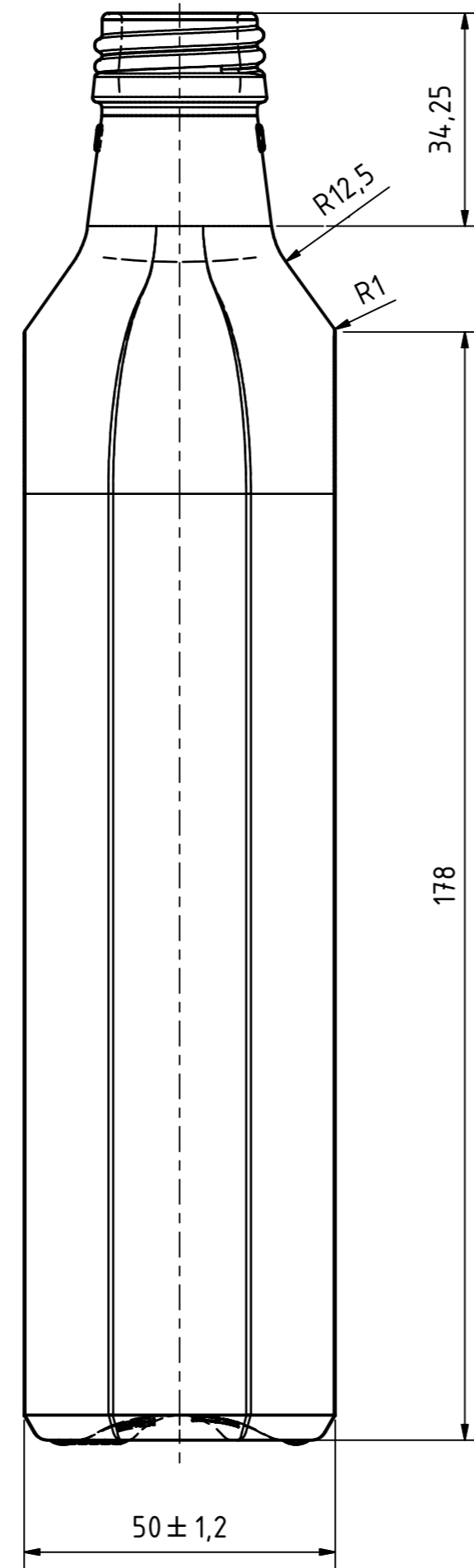
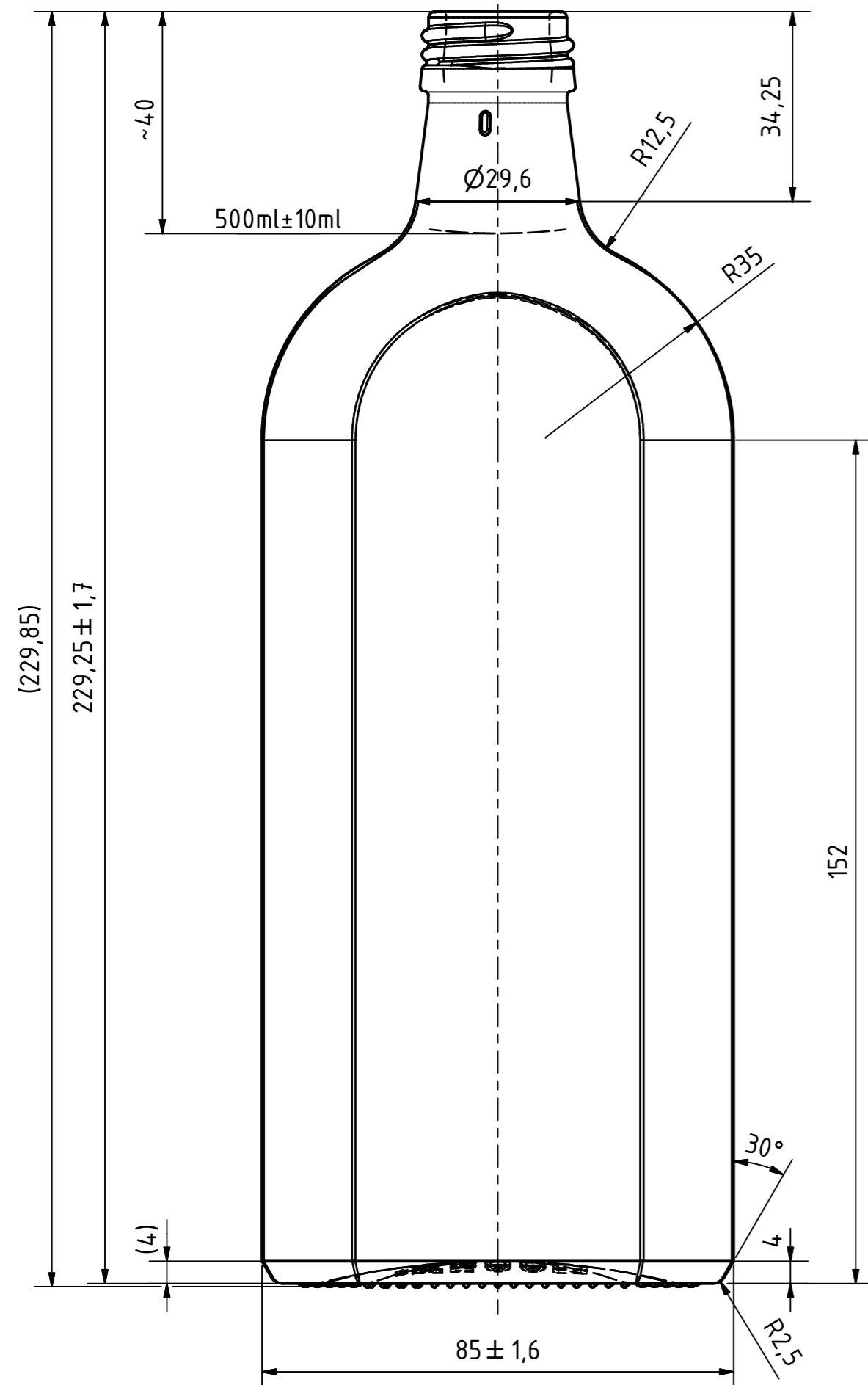

JEDNOCHODÝ ZÁVIT  
STOUPÁNÍ 3,39mm/1ot.  
ÚHEL STOUPÁNÍ, SKLON FRÉZY 2°22'  
SINGLE START THREAD  
THREAD PITCH 3,39mm/1rev.  
THREAD ANGLE, CUTTER ANGLE 2°22'

Plnicí objem (Filling Capacity)		Norma ústí (Standard of Finish)		Kreslil (Designer)	Endl	Datum (Date)	
500ml±10ml		SPEC 28x22				10.02.2021	
Skutečný objem (Brimfull Capacity)		Ústí (Drawing of Finish)		ZMĚNA (Modification)	DATUM (Date)	PODPIS (Sign)	INDEX (Index)
515ml±10ml							
Hmotnost (Glass Weight)	Min. otvor (Min. Through Bore)	Měřítka (Scale)					
cca 485g	Ø16mm	1 : 1					
Název (Name)				Číslo výkresu (Drawing Number)		Formát (Size)	
MEPLAT 0,5L B22				V-00921/0		A2	
Sklárny Moravia a.s.				List (Page) 1/1			